

RELEASE

DATE:

COMPANY:

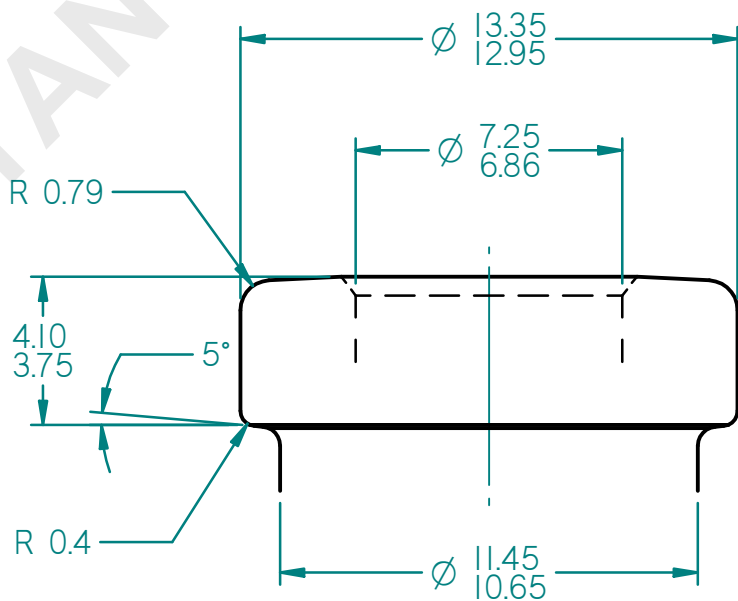
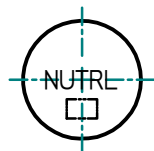
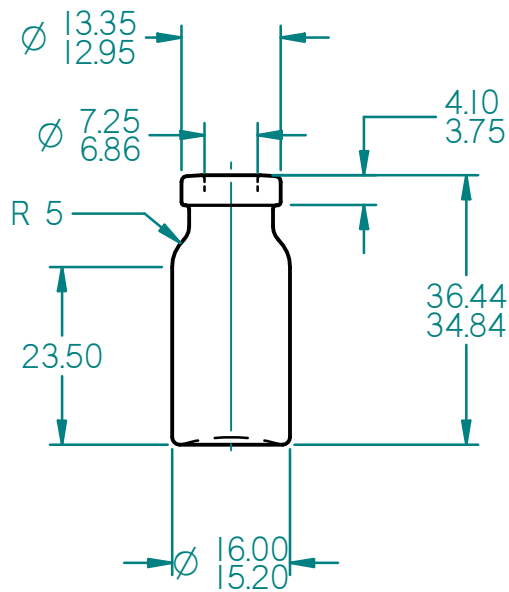

FINISH : 13 mm STD.

Protective note ISO 16016 observed

GENERAL TOLERANCES DIN 6129-1 (DIMENSIONS WITHOUT TOLERANCES ARE FOR REFERENCE ONLY)				FINISH: 13 mm STD.		O'FLOW CAPACITY: 2.70 - 3.30 ml		ARTICLE NO.:			
				FINISH DWG: NA.		WEIGHT: 7.0 g Approx.		5151210100			
				FINISH MOLD NO: 901		TYPE OF GLASS: I COLOUR: FLINT					
				DATE	NAME		TITLE: <h2 style="text-align: center;">2 ml METRO</h2>				
				DRAWN	12.10.2013 dipak						
				CHECKED	12.10.2013 H.B.P.						
				SCALE	1 : 1, 5 : 1						
				 NEUTRAL GLASS & ALLIED INDS. PVT. LTD. MUMBAI / KOSAMBA		MOLD NO.:	DRAWING NO.:		REVISION	SHEET	FORMAT
						001	B 1210		0	1 OF 1	A4
REV.	CHANGE	DATE	NAME	FILE: 2 ml METRO.dft							